

PUTAFDEKKINGEN DYNAMIC RM/17 CROSS GRIP

Toepassing: boor putafdekking
Geschikt voor zwaar verkeer,
drukke wegen, stadcentra, industrieterreinen...

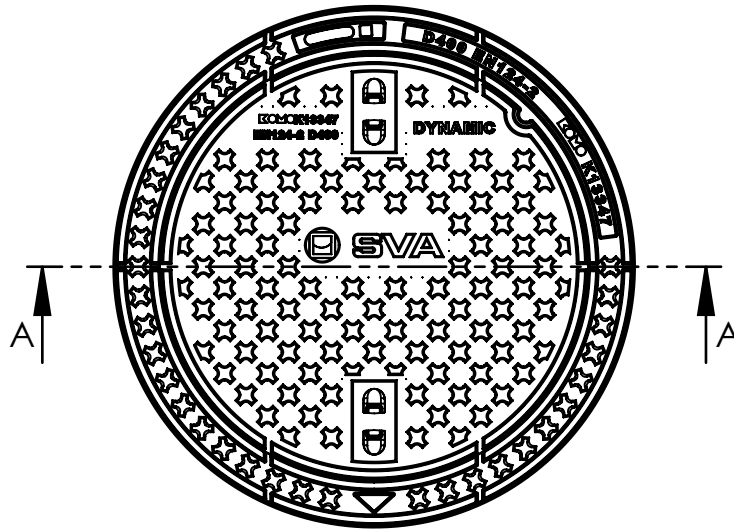

Bovenaanzicht



Toebehoren in Optie



Waaierdeksel open



Waaierdeksel dicht



Deksel met
ontluchtingsgaten
in de haalkommen



Roosterdeksel



Roosterdeksel
met waaierlogo

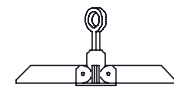

Stelhaak



Openingshaak
Putrand

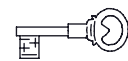

Vergrendeling

Doorsnede A-A

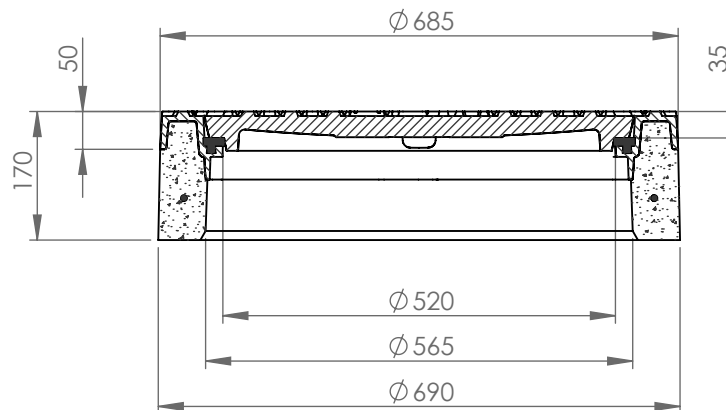

Kenmerken	DYNAMIC RM/17	Principe
Afmetingen	Ø 685x170 mm	Opschriften (alleen dicht deksel, overige op aanvraag)
Kwaliteit Rubber	SBR	Deksel rand
Mangaf	Ø 520 mm	Vuilwater VV
Gewicht deksel	54 kg	Regenwater RW
Gewicht rand	70 kg	Schoonwater SW
Gietijzer kwaliteit rand	GJL	Drain DW
Gietijzer kwaliteit rooster	GJL	Infiltratie IW
Keur	KOMO	
Belastingsklasse	D400	
Materiaal	Beton / GY	
Vergrendeling	Optie	

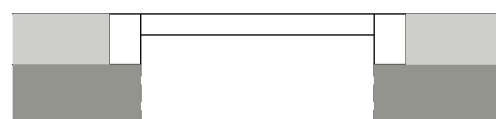

Plaatsingsvoorschriften op aanvraag

Afmetingen in mm - wijzigingen voorbehouden

o Product op verzoek (afname verplicht) / + standaard product / - niet leverbaar