

# STRAATKOLK EENDELIG

## P-Line MAX S1300/80 GB1

Toepassing:  
Afvoeren van hemelwater

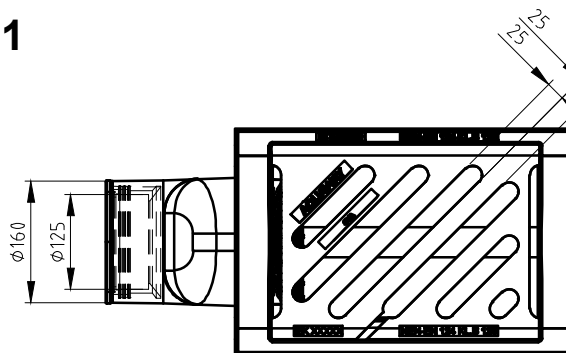

Bovenaanzicht

TOEBEHOR STANDAARD



Flexring

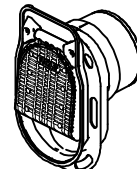

Scharnierende putklep

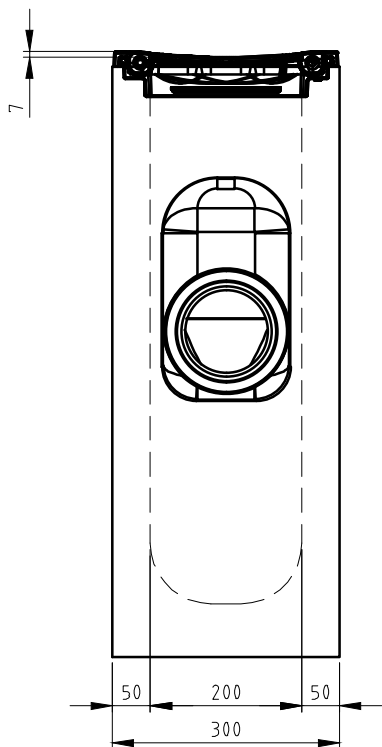

Zijaanzicht

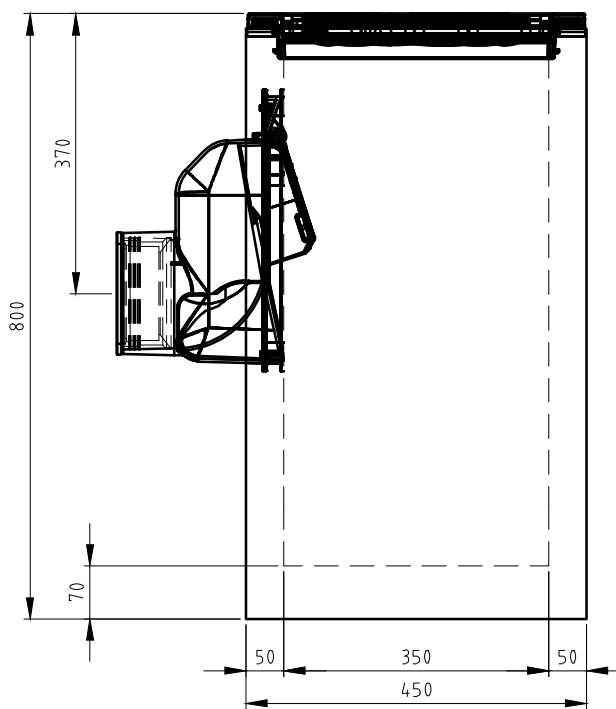

Vooraanzicht

TOEBEHOR IN OPTIE

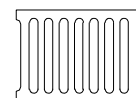

RS Rooster D400 met of zonder vergrendeling

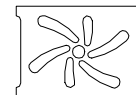

Waaierdeksel C250

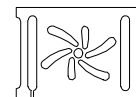

Waaierdeksel B125 met vergrendeling

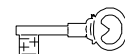

Vergrendeling

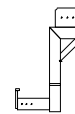

Stelhelp kolken

Kenmerken	P-Line MAX S1300/80 GB1	Principe													
Afmetingen	450x300x800 mm	<table border="1"> <tr> <td>aansluiting</td> <td>voor</td> <td>achter</td> <td>links</td> <td>rechts</td> </tr> <tr> <td></td> <td>-</td> <td>-</td> <td>+</td> <td>+</td> </tr> </table>				aansluiting	voor	achter	links	rechts		-	-	+	+
aansluiting	voor					achter	links	rechts							
	-	-	+	+											
Gewicht	144 kg														
Ø Aansluiting	DN125 FLEX/DN160														
Holling rooster	7 mm														
Rooster inlaatopeningen	320 cm <sup>2</sup>														
Stankslot	≥40 mm														
Zandvang	30 dm <sup>3</sup>														
Gietijzer kwaliteit rand	GJL														
Gietijzer kwaliteit rooster	GJS														
Keur	KOMO														
Verkeersbelastingsklasse	B125														
Materiaal	beton / GY														

Plaatsingsvoorschriften op aanvraag

afmetingen in mm - wijzigingen voorbehouden

o product op verzoek (afname verplicht) / + standaard product / - niet leverbaar