

STRAATKOLK EENDELIG

P-Line S1250/52 GB1

Toepassing:
Afvoeren van hemelwater

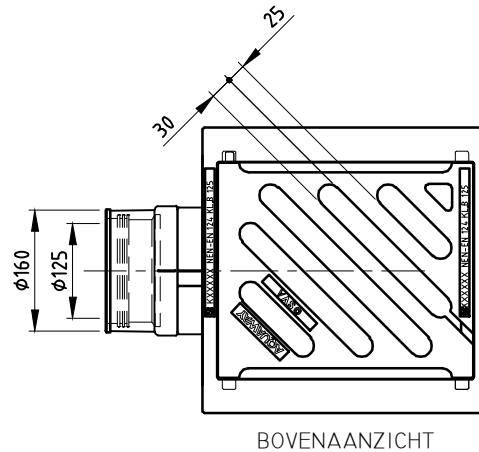

TOEBEHOOR STANDAARD

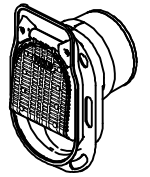

Scharnierende putklep

TOEBEHOOR IN OPTIE

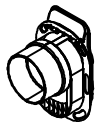

M-Line uitlaat Ø160

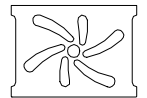

Waaierdeksel C250

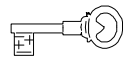

Vergrendeling

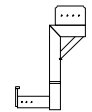

Stelhulp kolken

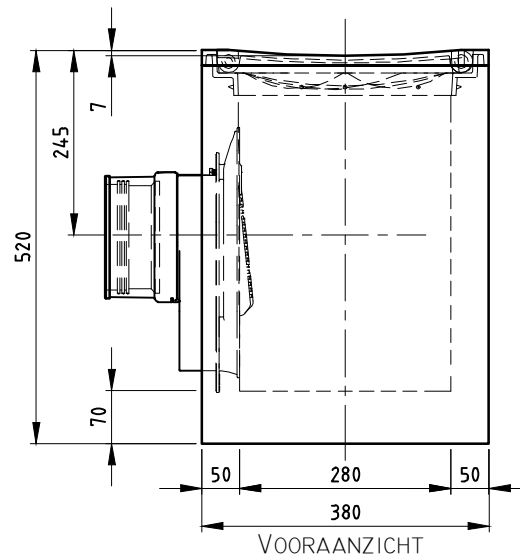
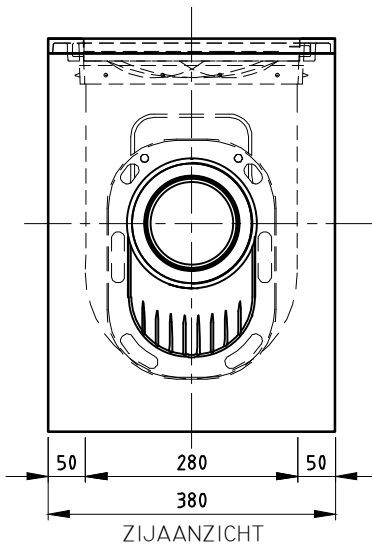

Kenmerken	P-Line S1250/52 GB1	Principe			
Afmetingen	380x380x520 mm	aansluiting			
Gewicht	110 kg				
Ø Aansluiting	DN125/DN160	voor	achter	links	rechts
Holling rooster	7 mm	-	+	+	+
Rooster inlaatopeningen	315 cm ²				
Stankslot	≥40 mm				
Zandvang	5 dm ³				
Gietijzer kwaliteit rand	GJL				
Gietijzer kwaliteit rooster	GJS				
Keur	KOMO				
Verkeersbelastingsklasse	B125				
Materiaal	beton / GY				
Voor bandprofiel	RWS 11/22 ; 11,5/22,5				

afmetingen in mm - wijzigingen voorbehouden

o product op verzoek (afname verplicht) / + standaard product / - niet leverbaar