

# STRAATKOLK EENDELIG

## P-Line S1260/90 GB1

Toepassing:  
Afvoeren van hemelwater

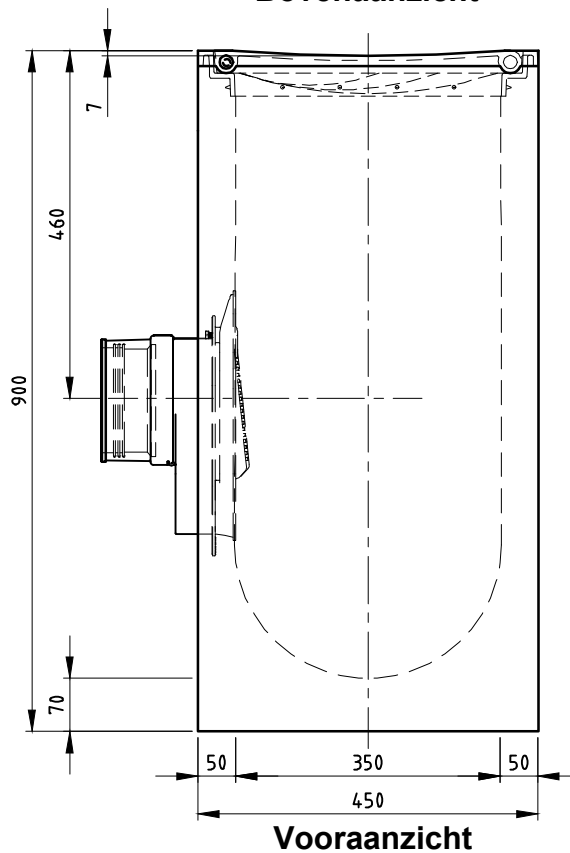
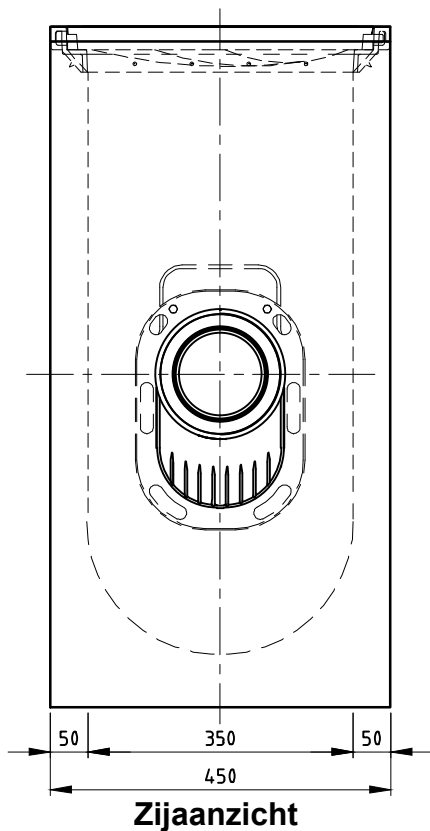
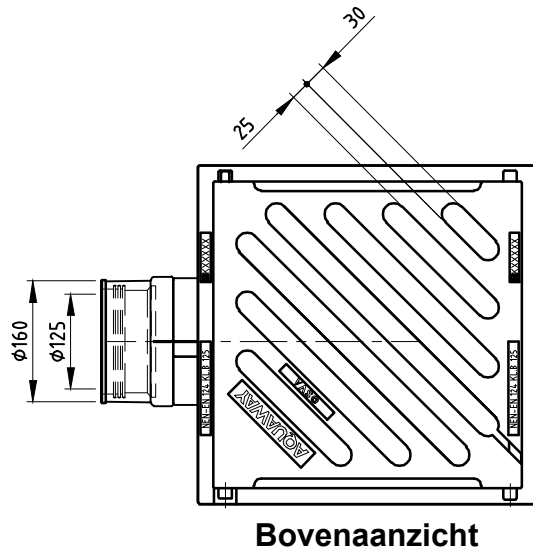

### TOEBEHOOR STANDAARD

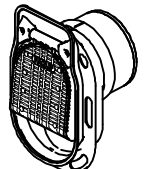
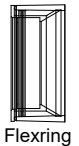

### TOEBEHOOR IN OPTIE

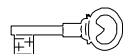
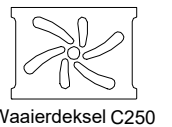

Vergrendeling

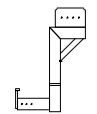

Stelhelp kolken

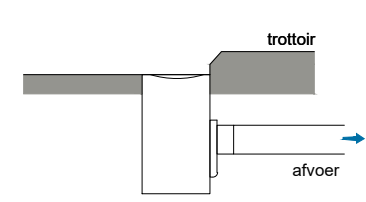
Kenmerken	P-Line S1260/90 GB1	Principe			
Afmetingen	450x450x900 mm	aansluiting			
Gewicht	225 kg	voor	achter	links	rechts
Ø Aansluiting	DN125 FLEX/DN160	-	+	+	+
Holling rooster	7 mm				
Rooster inlaatopeningen	463 cm <sup>2</sup>				
Stankslot	≥40 mm				
Zandvang	26 dm <sup>3</sup>				
Gietijzer kwaliteit rand	GJL				
Gietijzer kwaliteit rooster	GJS	Plaatsingsvoorschriften op aanvraag			
Keur	KOMO	afmetingen in mm - wijzigingen voorbehouden			
Verkeersbelastingsklasse	B125	o product op verzoek (afname verplicht) / + standaard product / - niet leverbaar			
Materiaal	beton / GY				

afmetingen in mm - wijzigingen voorbehouden

o product op verzoek (afname verplicht) / + standaard product / - niet leverbaar