

STRAATKOLKEN TWEEDELIG

AQUAWAY® S 2500-2520 P-LINE GB2

Toepassing:
Afvoeren van hemelwater,



Bovenaanzicht

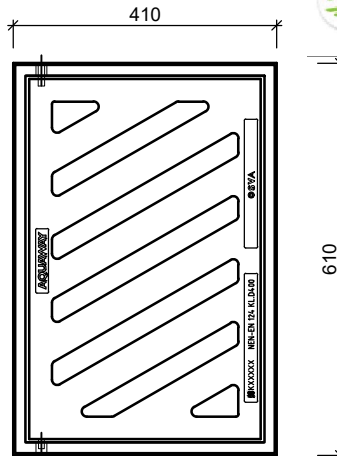

zijaanzichten

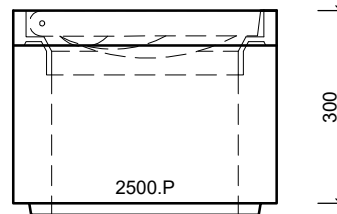
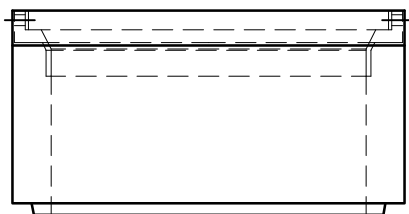

Standaard:

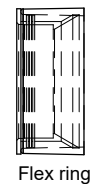

Flex ring

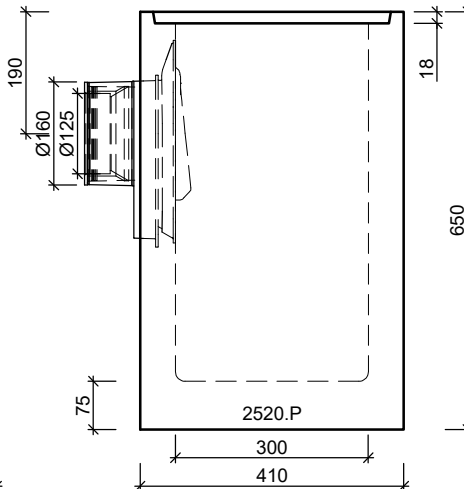
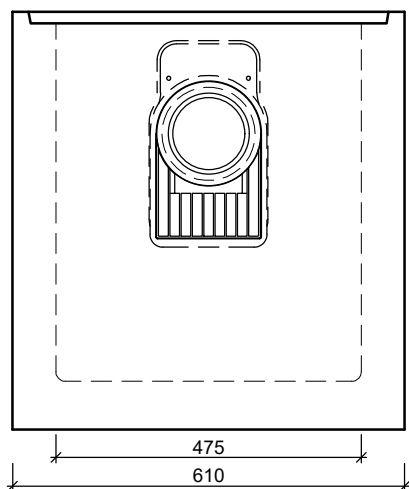

Scharnierende
Putklep

Toebehoren in optie:

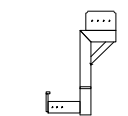

stelhulp kolken

Kenmerken	S 2500.P-2520.P P-LINE GB2	Principe
afmetingen	610/410/950mm	aansluiting
gewicht	BS 101kg / OB 192kg	voor - achter - links + rechts +
Ø aansluiting	FLEX DN125/DN160	
holling rooster	0mm	
rooster inlaatopeningen	600cm ²	
stankslot	≥ 40mm	
zandvang	> 20dm ³	
gietijzer kwaliteit rand	GJL	
gietijzer kwaliteit rooster	GJS	
keur	NL BSB	
verkeersbelastingsklasse	D400	
materiaal	beton / GY	

afmetingen in mm - wijzigingen voorbehouden

o product is een zoek (afname verspreid) / standaard product / - niet leverbaar