

GOOT STRAAKOLK EENDELIG

P-Line S-1360/60 GB1

Toepassing:

Afvoeren van hemelwater

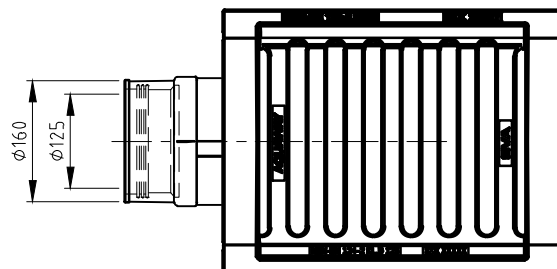

BOVENAANZICHT

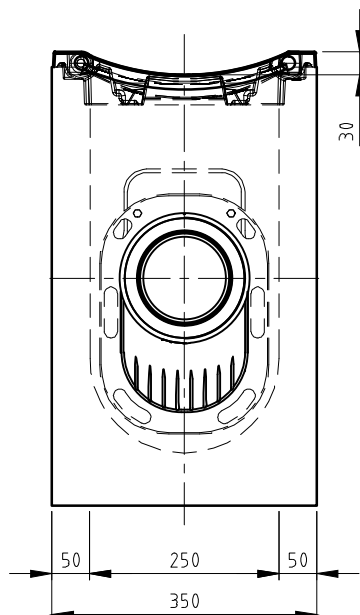

ZIJAANZICHT

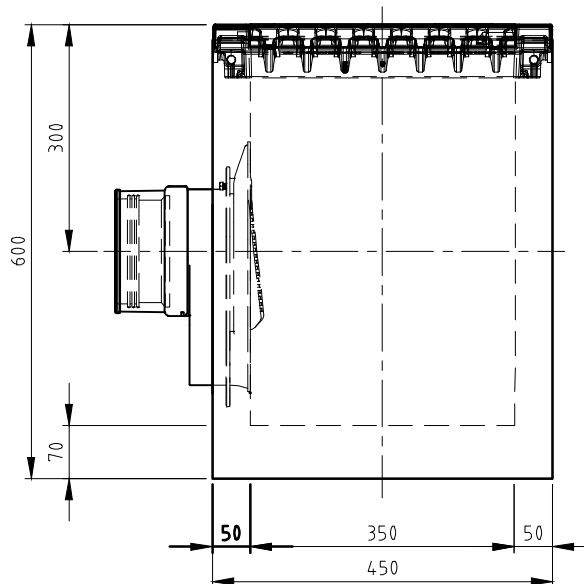

VOORAANZICHT

TOEBEHOR STANDAARD



Flexring

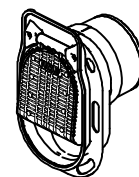

Scharnierende putklep

TOEBEHOR IN OPTIE

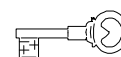

Vergrendeling

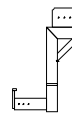

Stelhulp kolken

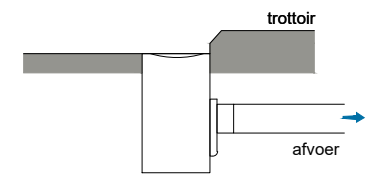
Kenmerken	P-Line S-1360/60 GB1	Principe																		
Afmetingen	450x350x600 mm	<table border="1"> <tr> <td>aansluiting</td> <td></td> <td></td> <td></td> <td></td> </tr> <tr> <td></td> <td>voor</td> <td>achter</td> <td>links</td> <td>rechts</td> </tr> <tr> <td></td> <td>-</td> <td>+</td> <td>+</td> <td>+</td> </tr> </table>				aansluiting						voor	achter	links	rechts		-	+	+	+
aansluiting																				
	voor	achter	links	rechts																
	-	+	+	+																
Gewicht	120 kg																			
Ø Aansluiting	DN125 FLEX/DN160																			
Holling rooster	30 mm																			
Rooster inlaatopeningen	520 cm ²																			
Stankslot	≥40 mm																			
Zandvang	9.5 dm ³																			
Gietijzer kwaliteit rand	GJL																			
Gietijzer kwaliteit rooster	GJS																			
Keur	KOMO																			
Verkeersbelastingsklasse	B125																			
Materiaal	beton / GY																			
																				
		Plaatsingsvoorschriften op aanvraag																		

afmetingen in mm - wijzigingen voorbehouden

o product op verzoek (afname verplicht) / + standaard product / - niet leverbaar